

SAKAI®

R2-2 R2-2K Series

Asphalt Roller



R2-2

World standard originally patented by Sakai in 1970s

Static Three Wheel Roller

Versatile static three wheel roller for various types of paving compaction jobs

Best compaction quality and efficiency

- Equal static linear pressure across all drums provides uniform compaction.
- Articulated centre-point steering.
- The all-drum hydrostatic drive with the largest diameter drums leaves a smooth finish and minimizes pushing and shoving of hot mix asphalt (HMA) mat.
- Applicable to thin HMA layers such as SMA and OGFC where vibratory compaction is not allowed.

High safety standards

- 1 m × 1 m visibility.
- Emergency brake pedal is standard.

Easy Maintenance

- Easy access to engine, hydraulics, devices, filters, etc. from ground.
- Sprinkler system with anti-clog package, i.e., a plastic water tank, triple-protection filtration, etc., and with perfect draining winterization.
- Direct access to spray nozzles from operators station.
- Rugged articulated center-pin joint.
- KUBOTA V3307 engine features OHV4 valve and Turbo that maintains output even at high elevations.

See in detail at Sakai Web site

www.sakainet.co.jp

R2-2 R2-2K Series

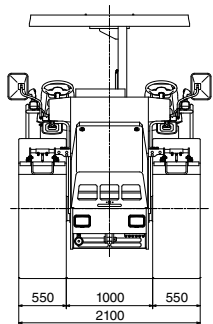

R2-2

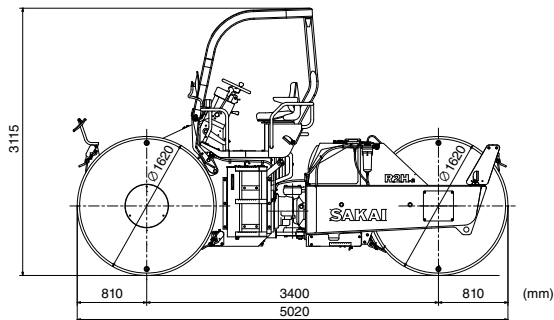
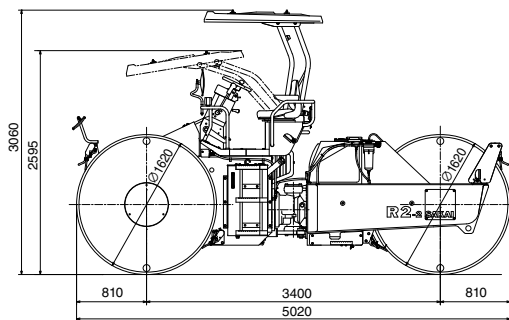

R2H-2

TYPE		Static Three Wheel Roller				
MODEL		R2-2	R2H-2	R2-2K	R2H-2K	
CHASSIS MODEL		1R5		1R6		
WEIGHTS	Operating weight (with AWNING)	kg (lb)	9,980 (22,005)	14,345 (31,625)*	9,980 (22,005)	13,995 (30,855)
	Empty weight (with AWNING)	kg (lb)	9,300 (20,500)	10,485 (23,115)*	9,300 (20,500)	10,135 (22,345)
	Load on front axle (operating weight) (with AWNING)	kg (lb)	4,880 (10,760)	7,050 (15,540)*	4,880 (10,760)	6,795 (14,980)
	Load on rear axle (operating weight) (with AWNING)	kg (lb)	5,100 (11,245)	7,295 (16,085)*	5,100 (11,245)	7,200 (15,875)
PERFORMANCE	Static linear pressure for front roll (operating weight) (with AWNING)	N/cm (lb/in)	435 (248)	629 (359)*	435 (248)	606 (346)
	Static linear pressure for rear roll (operating weight) (with AWNING)	N/cm (lb/in)	455 (260)	650 (371)*	455 (260)	642 (367)
	No. of speeds		2			
	Speed range (L / H)	km / h (mph)	0 - 8 / 0 - 16 (0 - 5.0 / 0 - 9.9)			
DIMENSIONS	Gradability	% (°)	47 (25)	31 (17)	47 (25)	31 (17)
	Min. turn radius (outer)	m (in)	6.3 (248)			
	Overall length	mm (in)	5,020 (198)			
	Overall width	mm (in)	2,100 (83)			
	Overall height (with AWNING)	mm (in)	3,060 (120)	3,115 (123)*	3,060 (120)	
	Wheelbase	mm (in)	3,400 (134)			
	Compaction width	mm (in)	2,100 (83)			
ENGINE	Drum diameter / Drum width / Number of Rolls	mm (in)	front : 1,620 (64) / 550 (22) / 2 rear : 1,620 (64) / 1,100 (43) / 1			
	Ground clearance	mm (in)	340 (13.5)			
	Curb clearance	mm (in)	∞			
	Side clearance	mm (in)	0			
	Make		KUBOTA			
POWER LINE	Model		V3307 - DI - T - KDN (Interim Tier4)		V3307-DI-T-E2B-RRSH1	
	Type		Diesel, Water-cooled, 4cycle, 4cylinder with turbo charger			
	Displacement	L (cu.in)	3.331 (203)			
	Rated output	kW (HP)/min ⁻¹	55.4 (74) / 2,200			
	Electric system battery	V (VAh× Qty)	12 (12 / 72 × 1)			
	Electric system alternator	V/A	12 / 80			
BRAKE SYSTEM	Transmission		Hydrostatic transmission			
	Type		Hydraulic			
	Drive wheel		All wheel			
STEERING SYSTEM	Service (emergency)		Hydrostatic + SAHR / Brake Pedal			
	Parking		Spring-applied, hydraulically released type (SAHR) / Panel Button			
	Working (nominal)		Hydrostatic dynamic brake through drive system / F&R Lever			
FLUID CAPACITY	Type		Hydraulic type (Articulated)			
	Articulation / Oscillation (+/-)	°	36 / 5.3			
FLUID CAPACITY	Fuel tank	L (gal)	100 (26)			
	Hydraulic tank	L (gal)	85 (22.5)			
	Sprinkler tank	L (gal)	680(180)			

- Operating Weight : 100% Fuel, 100% Water, No Operator.
- Specifications are subject change without notice.
- All units are SI units. Inside of () is for reference units.
- Above specified numbers could be deviated within ±5%.
- * With ROPS

- ※ Engine meets EPA standards for R2-2 series.
- ※ Using low quality fuel may cause engine failure.



ISO 9001 Certification



SAKAI HEAVY INDUSTRIES, LTD.

HEAD OFFICE: 1-4-8, SHIBA DAIMON, MINATO-KU, TOKYO JAPAN

TELEPHONE: +81-3-3431-9971

FACSIMILE: +81-3-3436-6212

Standard Equipment :

- Instrument ● Gauges ● Scrapers for both directions ● Back up alarm ● Horn
- AWNING (R2-2, R2-2K, R2H-2K) ● ROPS CANOPY (R2H-2)
- Sliding seat ● Head light ● Working light ● Turn signale lamp ● Mirrors
- Pressurized water sprinkler system ● Intermittent water spray timer ● 4 points lifting

Optional Equipment :

- Rotary lamp ● WATER BALLAST (R2H-2, R2H-2K) (3.18t)